

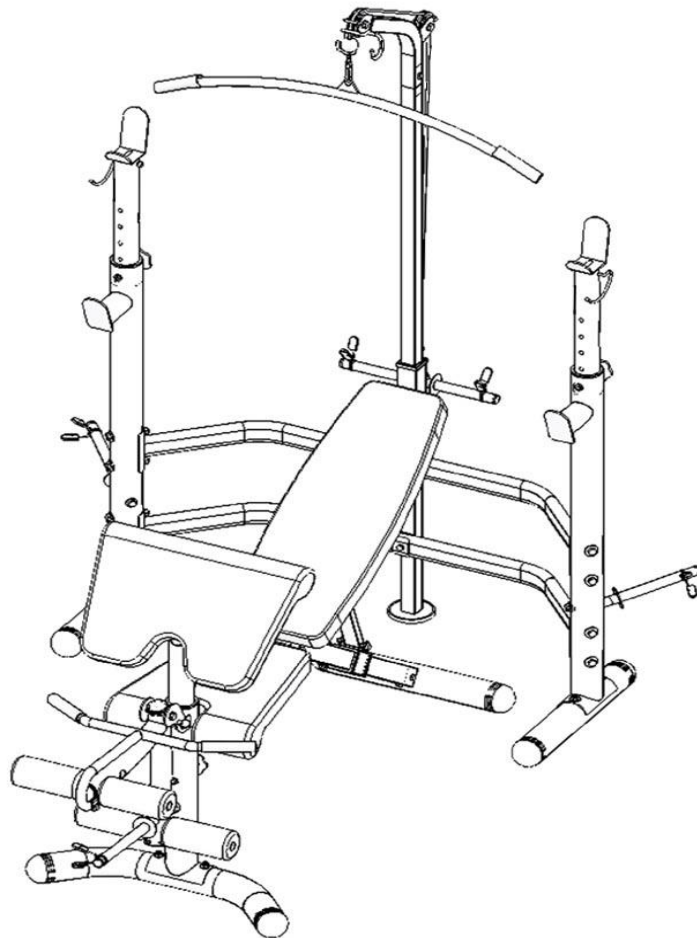

**USER MANUAL – EN**

**IN 4069 Multi-Function Bench inSPORTline Bastet**



# CONTENTS

IMPORTANT SAFETY INFORMATION ..... 3

EXPLODED VIEW ..... 4

PARTS LIST ..... 5

ASSEMBLY INSTRUCTIONS ..... 7

EXERCISE INSTRUCTIONS ..... 10

TERMS AND CONDITIONS OF WARRANTY, WARRANTY CLAIMS..... 11

## IMPORTANT SAFETY INFORMATION

**Please keep this manual in a safe place for reference.**

1. It is important to read this entire manual before assembling and using the equipment. Safe and efficient use can only be achieved if the equipment is assembled, maintained and used properly. It is your responsibility to ensure that all users of the equipment are informed of all warnings and precautions.
2. Before starting any exercise program you should consult your doctor to determine if you have any physical or health conditions that could create a risk to your health and safety, or prevent you from using the equipment properly. Your doctor's advice is essential if you are taking medication that affects your heart rate, blood pressure or cholesterol level.
3. Be aware of your body's signals. Incorrect or excessive exercise can damage your health. Stop exercising if you experience any of the following symptoms: Pain, tightness in your chest, irregular heartbeat, extreme shortness of breath, feeling light headed, dizzy or nauseous. If you do experience any of these conditions you should consult your doctor before continuing with your exercise program.
4. Keep children and pets away from the equipment. The equipment is designed for adult use only.
5. Use the equipment on a solid, flat level surface with a protective cover for your floor or carpet. For safety, the equipment should have at least 0.6 meter of free space all around it.
6. Before using the equipment, check the nuts and bolts are securely tightened.
7. The safety level of the equipment can only be maintained if it is regularly examined for damage and/or wear and tear.
8. Always use the equipment as indicated. If you find any defective components whilst assembling or checking the equipment, or if you hear any unusual noise coming from the equipment during use, stop exercising. Do not use the equipment until the problem has been rectified.
9. Wear suitable clothing whilst using the equipment. Avoid wearing loose clothing which may get caught in the equipment or that may restrict or prevent movement. Please realize that incorrect and excessive training can possibly cause health problems.
10. The equipment is suitable for domestic, home use only. Maximum weight of user: 150kg.
11. The equipment is not suitable for therapeutic use.
12. Care must be taken when lifting or moving the equipment so as not to injure your back. Always use proper lifting techniques and/or use assistance.

# EXPLODED VIEW

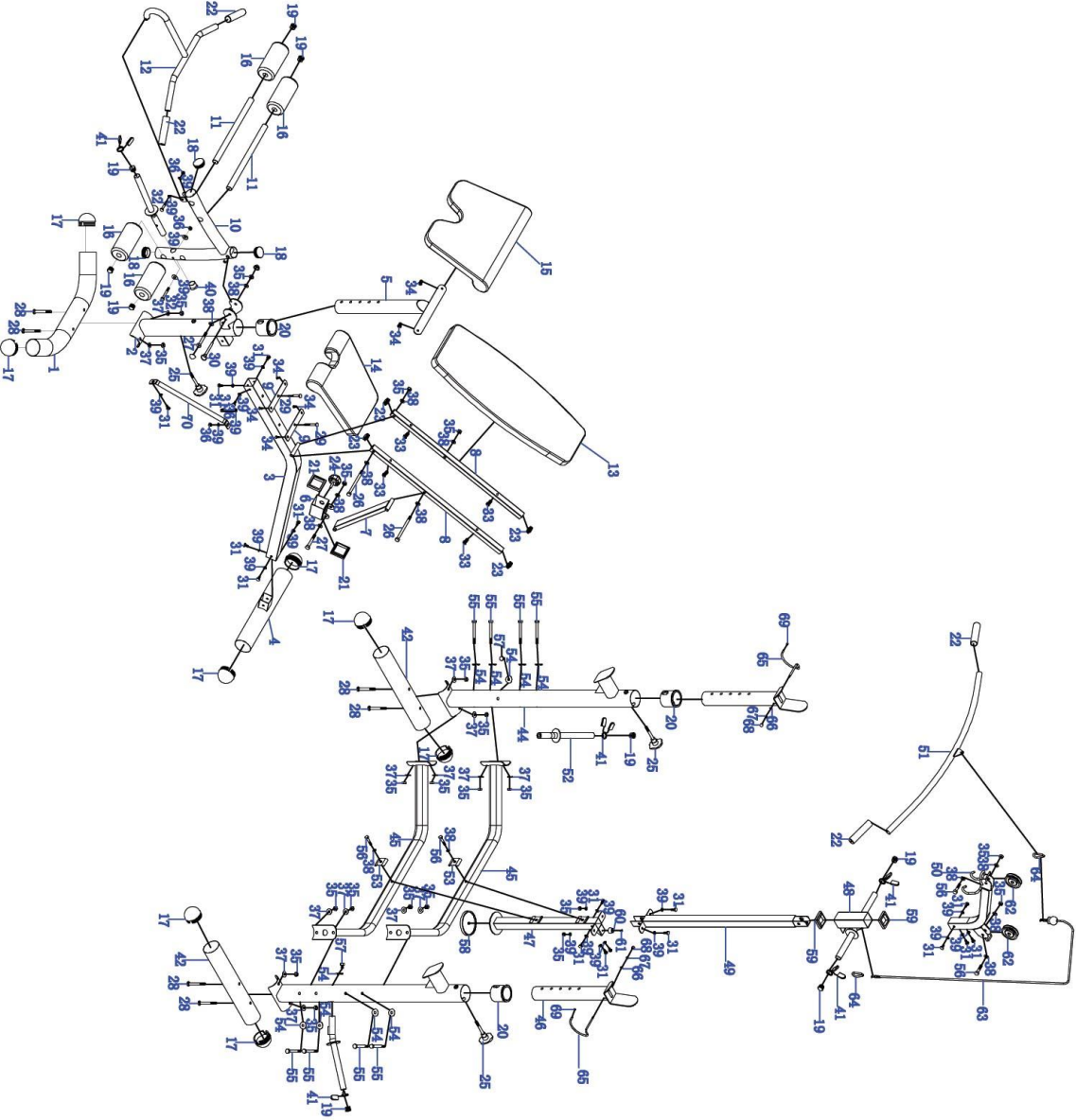

## PARTS LIST

NO.	Description	Qty
1	Front Base Tube	1
2	Leg Extension Upright	1
3	Main Frame	1
4	Rear Stabilizer	1
5	Arm Curl Frame	1
6	Sliding Block	1
7	Backrest Adjustment Bar	1
8	Backrest Bar	2
9	Seat Bracket	2
10	Leg Extension	1
11	Foam Tube	2
12	Handle Bar	1
13	Backrest Pad	1
14	Seat Pad	1
15	Arm Curl	1
16	Foam	4
17	Round End Cap (Φ 76)	8
18	Round End Cap (Φ 50)	3
19	Round End Cap (Φ 25)	9
20	Plastic Spacer (Φ 76V Φ 60)	3
21	Plastic Spacer(□ 60V □ 50)	2
22	Handle Grip (Φ 32V Φ 23*120)	4
23	Square End Cap (□ 25)	4
24	Knob (M16*22)	1
25	Knob (M10*75)	3
26	Bolt (M10*145)	2
27	Bolt (M10*75)	2
28	Bolt (M10*90)	6
29	Bolt (M8*65)	2
30	Cross Pin (Φ 8*65)	1
31	Bolt (M8*15)	15
32	Bolt (M8*45)	2
33	Bolt (M6*40)	4
34	Bolt (M6*14)	6
35	Locknut (M10)	21

36	Locknut (M8)	4
37	Curved Washer (M10)	14
38	Flat Washer (M10)	14
39	Flat Washer (M8)	22
40	End Cap ( $\Phi$ 25)	1
41	Spring Clip ( $\Phi$ 25)	5
42	Base Tube	2
43	Upright Tube (Left)	1
44	Upright Tube (Right)	1
45	Girder Frame	2
46	Crutch Tip	2
47	Lat Tower Base	1
48	Glide Carriage	1
49	Lat Connecting	1
50	Lat Tower (Upper)	1
51	Lat Tower Handle Bar	1
52	Weight Plate Storage Bar	2
53	Connecting Plate	2
54	Washer (M10)	10
55	Bolt (M10*95)	8
56	Bolt (M10*45)	4
57	Bolt (M10*15)	2
58	Stabilizer Pad ( $\Phi$ 100)	1
59	Plastic Spacer ( $\square$ 50V $\square$ 38)	2
60	Rubber Bumper( $\Phi$ 25)	1
61	Bolt (M5*10)	1
62	Pulley( $\Phi$ 25)	2
63	Lat Cable	1
64	Carabineer	2
65	Safety Hook	2
66	Flat Washer (M6)	2
67	Locknut (M6)	2
68	Nut Cap (M6)	2
69	Safety Hook Cap	2
70	Reinforcement Bar	1

# ASSEMBLY INSTRUCTIONS

	<p><b>STEP 1</b></p> <p>Assembly the Leg Extension Upright (2) to the Front Base Tube (1), and then fasten the Bolt (28), the Washer (37) and the Locknut (35). Assembly the Main Frame (3) to Leg Extension Upright (2), also fixed it with Bolt (31) and the Flat Washer (39). Assembly the Sliding Block (6) to the Main Frame (3), and then attach the Rear Stabilizer (4) to the Main Frame (3) fixed with Bolt (31) and the Flat Washer (39). Last, put the Seat Bracket (9) to the Main Frame (3) fixed with Bolt (29), the Flat Washer (39) and the Locknut (36) and through with Reinforcement Bar (70). The other side of Reinforcement Bar (70) connecting with Leg Extension Upright (2) using Flat Washer (39) and Locknut (31).</p>
	<p><b>STEP 2</b></p> <p>Assembly the Backrest adjustment Bar (7) to the Sliding Block (6), and connect the Bolt (27), the Flat Washer (38) and the Locknut (35) to fix it. The backrest Bar (8) to the Main Frame (3) and the Backrest Adjustment Bar (7) separately fixed with the Bolt (26), the Flat Washer (38) and the Locknut (35). Put the backrest pad (13) to the backrest Bar (8) fixed with the Bolt (33), and then attach the Seat Pad (14) to the Seat Bracket (9) fixed with the bolt (34). Assembly the ankle bar to the Leg Extension Upright (2) and fix it with Knob (25).</p>

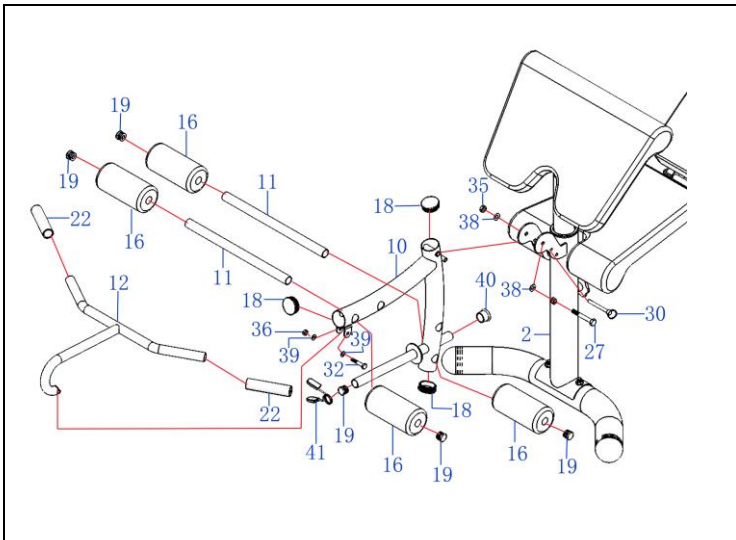

**STEP 3**

Attach the Leg Extension (10) to the Leg Extension Upright (2) fixed with Bolt (27), the Flat Washer (38), Locknut (35) and the Cross Pin (30). Then attach the Foam (16) to the Foam Tube (11), Holder Grip (22) to the Handle Bar (12), attach the Handle Bar (12) to the Leg Extension (10) fixed with the Bolt (32), the Flat Washer (39) and the Locknut (36).

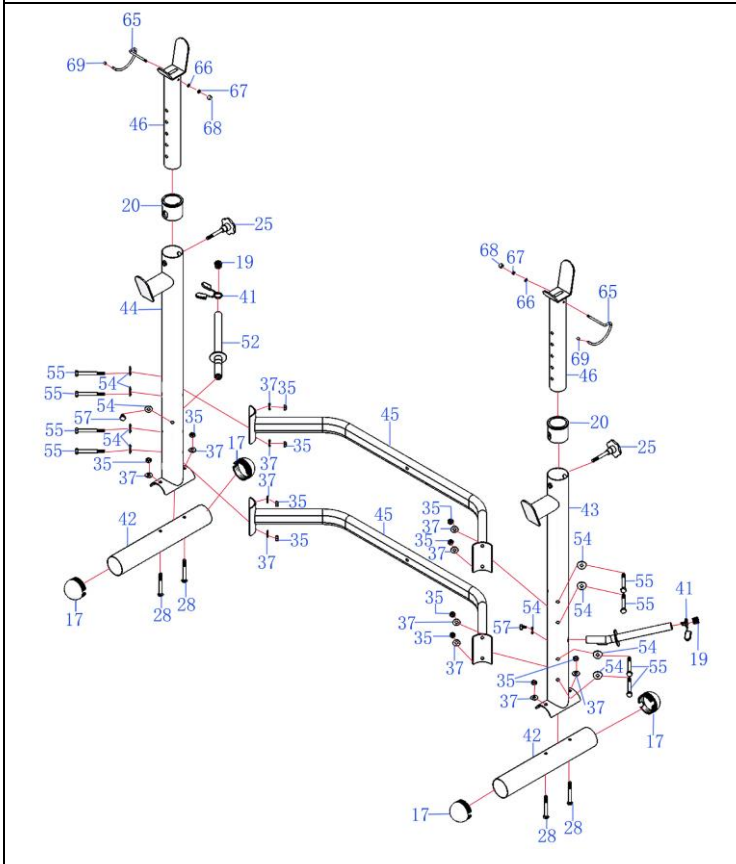

**STEP 4**

Assemble the Base Tube (42) to two Upright Tubes (43) and (44) separately fixed with Bolt (28), the washer (37) and the locknut (35), and then connect the two Upright Tubes (43) and (44) through the Girder Frame (45) fixed with the Washer (54), the Bolt (55), the Washer (37) and the Locknut (35). Attach the Crutch Tip (46) to the Upright Tube (43) and (44) fixed with the Knob (25), and then assembly the safety hook (65) to the Crutch Tip (46) fastening the Locknut (67),the Flat Washer (66) and the Nut Cap (68). Assemble the Weight Plate Storage Bar (52) to the upright Tube (43) and (44) separately fixed with the Bolt (57) and the Washer (54). And then assembly the safety hook Cap (69) to the Safety Hook(65), Spring Clip(41) to the Weight Plate Storage Bar (52).



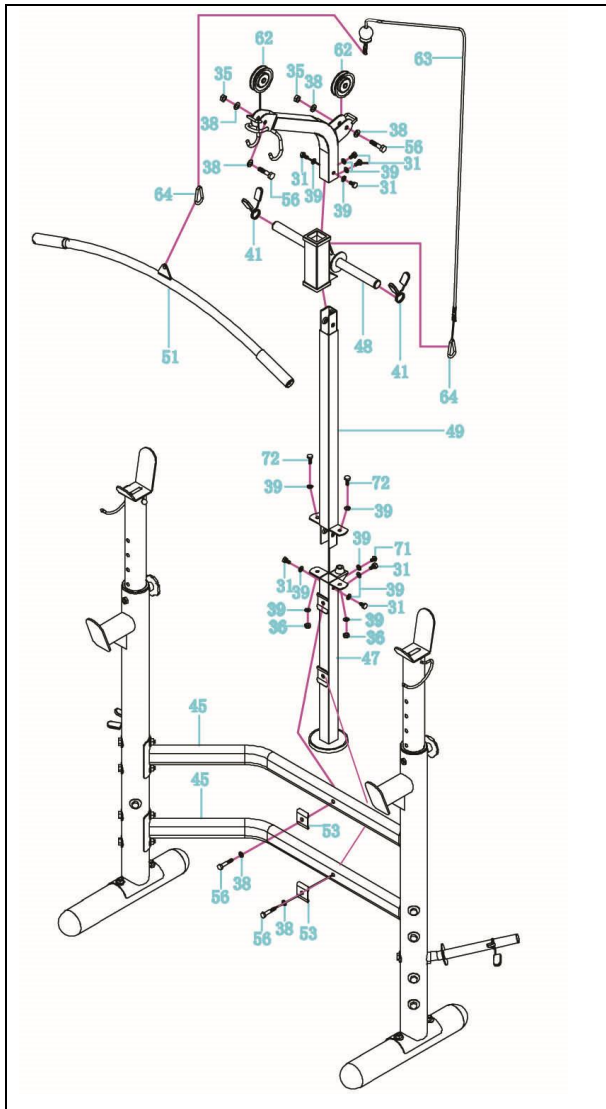

### STEP 5

Assemble the Lat Tower Base (47) to the Rear Cross Tube (45) fixed with the Connecting Plate (53), Bolt (56) and the Flat Washer (38). Attach the Lat Connecting (49) to the Lat Tower Base (47) fixed with the Bolt (31), the Flat Washer (39) and Locknut (35). Solid the Glide Carriage (48) to the Lat Connecting (49), the Lat Tower (Upper)(50) to the Lat Connecting (49) fixed with the Bolt (31) and the Flat Washer (39). Assemble the Lat Cable (63) to the Pulley (62), and put the roller (62) onto the lat upper end (50) fixed with the Bolt (56), the Flat Washer (38) and the Locknut (35). Connect the Lat Cable (63) with the Glide Carriage (48) through the Carabiner (64). At last, connect the Lat Tower Handle Bar (51) with the Lat Cable (53) through the Carabiner (64).

# EXERCISE INSTRUCTIONS

Using your Weight bench will provide you with several benefits, it will improve your physical fitness, tone muscle and in conjunction with calorie controlled diet help you lose weight.

## 1. The Warm Up Phase

This stage helps get the blood flowing around the body and the muscles working properly. It will also reduce the risk of cramp and muscle injury. It is advisable to do a few stretching exercises as shown below. Each stretch should be held for approximately 30 seconds, do not force or jerk your muscles into a stretch – if it hurts, STOP.

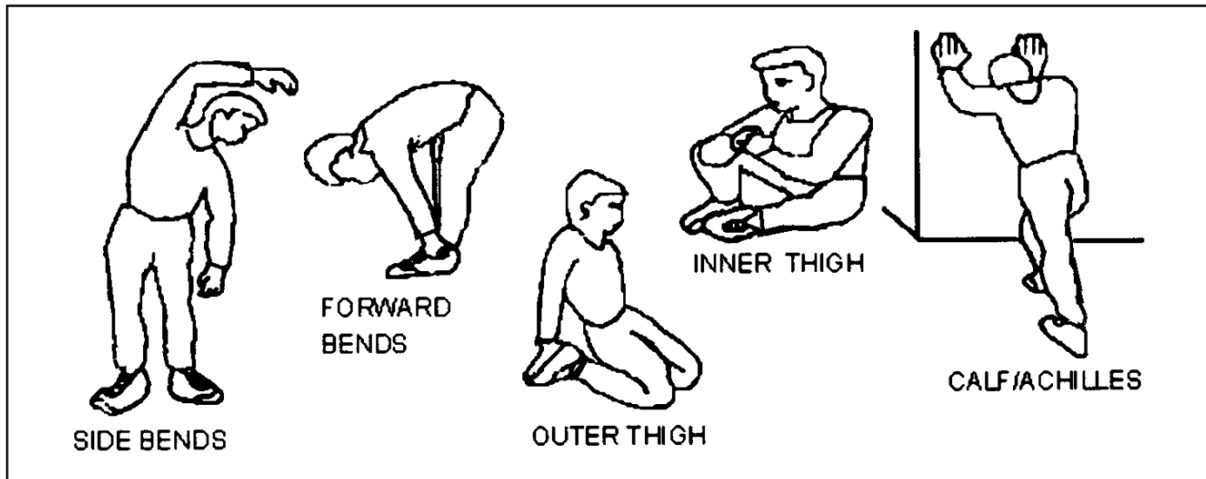

## 2. The Exercise Phase

This is the stage where you put the effort in. After regular use, use muscles in your body will become more flexible. Work to your own pace but it is very important to maintain a steady tempo throughout. The rate of work should be sufficient to raise your heart beat into the target zone shown on the graph below.

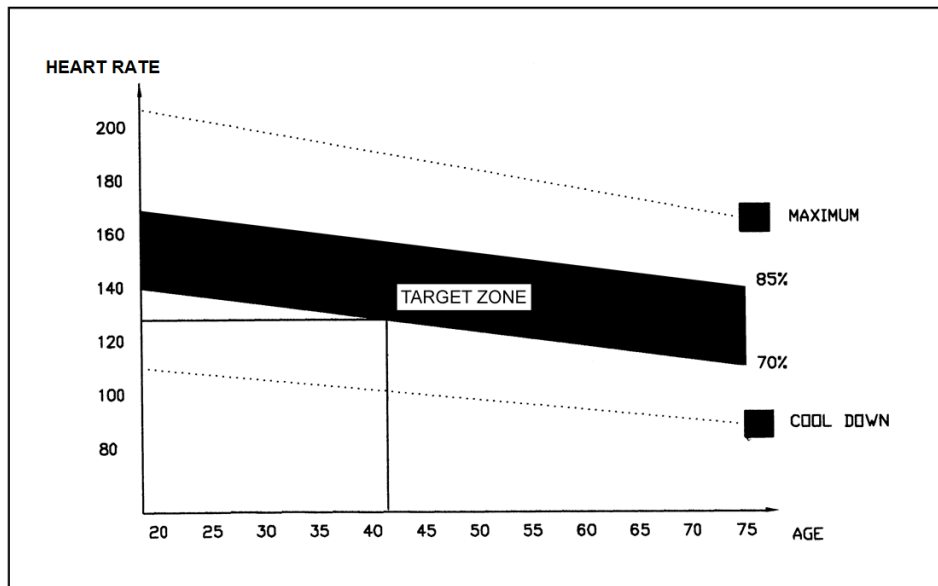

This stage should last for a minimum of 12 minutes though most people start at about 15-20 minutes.

## 3. The Cool Down Phase

This stage is to let your Cardio-vascular System and muscles wind down. This is a repeat of the warm up exercise e.g. reduce your tempo, continue for approximately 5 minutes. The stretching exercises should now be repeated, again remembering not to force or jerk your muscles into the stretch.

As you get fitter you may need to train longer and harder. It is advisable to train at least three times a week, and if possible space your workouts evenly throughout the week.

### **MUSCLE TONING**

To tone muscle while on your Weight bench you will need to put more weight disc. This will put more strain on your muscle and may mean you cannot train for as long as you would like. If you are also trying to improve your fitness you need to alter your training program. You should train as normal during the warm up and cool down phase, but towards the end of the exercise phase you should increase resistance making your muscle work harder. You will have to reduce your speed to keep your heart rate in the target zone.

### **WEIGHT LOSS**

The important factor here is the amount of effort you put in. The harder and longer you work the more calories you will burn. Effectively this is the same as if you were training to improve your fitness, the difference is the goal.

### **USE**

The seat height and angle can be adjusted by removing the adjustment knob and raising or lowering the seat. There are 10 holes in the seat support tube allowing for a range of heights. Once the correct height has been chosen, refit the adjustment knob and tighten.

## **TERMS AND CONDITIONS OF WARRANTY, WARRANTY CLAIMS**

### **General Conditions of Warranty and Definition of Terms**

All Warranty Conditions stated hereunder determine Warranty Coverage and Warranty Claim Procedure. Conditions of Warranty and Warranty Claims are governed by Act No. 40/1964 Coll. Civil Code, Act No. 513/1991 Coll., Commercial Code, and Act No. 634/1992 Coll., Consumer Protection Act, as amended, also in cases that are not specified by these Warranty rules.

The seller is SEVEN SPORT s.r.o. with its registered office in Borivojova Street 35/878, Prague 13000, Company Registration Number: 26847264, registered in the Trade Register at Regional Court in Prague, Section C, Insert No. 116888.

According to valid legal regulations it depends whether the Buyer is the End Customer or not.

“The Buyer who is the End Customer” or simply the “End Customer” is the legal entity that does not conclude and execute the Contract in order to run or promote his own trade or business activities.

“The Buyer who is not the End Customer” is a Businessman that buys Goods or uses services for the purpose of using the Goods or services for his own business activities. The Buyer conforms to the General Purchase Agreement and business conditions to the extent specified in the Commercial Code.

These Conditions of Warranty and Warranty Claims are an integral part of every Purchase Agreement made between the Seller and the Buyer. All Warranty Conditions are valid and binding, unless otherwise specified in the Purchase Agreement, in the Amendment to this Contract or in another written agreement.

### **Warranty Conditions**

#### **Warranty Period**

The Seller provides the Buyer a 24 months Warranty for Goods Quality, unless otherwise specified in the Certificate of Warranty, Invoice, Bill of Delivery or other documents related to the Goods. The legal warranty period provided to the Consumer is not affected.

By the Warranty for Goods Quality, the Seller guarantees that the delivered Goods shall be, for a certain period of time, suitable for regular or contracted use, and that the Goods shall maintain its regular or contracted features.

#### **The Warranty does not cover defects resulting from:**

User's fault, i.e. product damage caused by unqualified repair work, improper assembly, insufficient insertion of seat post into frame, insufficient tightening of pedals and cranks

Improper maintenance

Mechanical damages

Regular use (e.g. wearing out of rubber and plastic parts, joints etc.)

Unavoidable event, natural disaster

Adjustments made by unqualified person

Improper maintenance, improper placement, damages caused by low or high temperature, water, inappropriate pressure, shocks, intentional changes in design or construction etc.

### **Warranty Claim Procedure**

The Buyer is obliged to check the Goods delivered by the Seller immediately after taking the responsibility for the Goods and its damages, i.e. immediately after its delivery. The Buyer must check the Goods so that he discovers all the defects that can be discovered by such check.

When making a Warranty Claim the Buyer is obliged, on request of the Seller, to prove the purchase and validity of the claim by the Invoice or Bill of Delivery that includes the product's serial number, or eventually by the documents without the serial number. If the Buyer does not prove the validity of the Warranty Claim by these documents, the Seller has the right to reject the Warranty Claim.

If the Buyer gives notice of a defect that is not covered by the Warranty (e.g. in the case that the Warranty Conditions were not fulfilled or in the case of reporting the defect by mistake etc.), the Seller is eligible to require a compensation for all the costs arising from the repair. The cost shall be calculated according to the valid price list of services and transport costs.

If the Seller finds out (by testing) that the product is not damaged, the Warranty Claim is not accepted. The Seller reserves the right to claim a compensation for costs arising from the false Warranty Claim.

In case the Buyer makes a claim about the Goods that is legally covered by the Warranty provided by the Seller, the Seller shall fix the reported defects by means of repair or by the exchange of the damaged part or product for a new one. Based on the agreement of the Buyer, the Seller has the right to exchange the defected Goods for a fully compatible Goods of the same or better technical characteristics. The Seller is entitled to choose the form of the Warranty Claim Procedures described in this paragraph.

The Seller shall settle the Warranty Claim within 30 days after the delivery of the defective Goods, unless a longer period has been agreed upon. The day when the repaired or exchanged Goods is handed over to the Buyer is considered to be the day of the Warranty Claim settlement. When the Seller is not able to settle the Warranty Claim within the agreed period due to the specific nature of the Goods defect, he and the Buyer shall make an agreement about an alternative solution. In case such agreement is not made, the Seller is obliged to provide the Buyer with a financial compensation in the form of a refund.



### **SEVEN SPORT s.r.o.**

Registered Office:	Borivojova 35/878, 130 00 Praha 3, Czech Republic
Headquarters:	Delnicka 957, 749 01 Vitkov, Czech Republic
Warranty & Service Centre:	Cermenska 486, 749 01 Vitkov, Czech Republic
CRN:	26847264
VAT ID:	CZ26847264
Phone:	+420 556 300 970
E-mail:	eshop@insportline.cz reklamace@insportline.cz servis@insportline.cz
Web:	www.insportline.cz

---

**SK**

**INSPORTLINE s.r.o.**

Headquarters, Warranty & Service centre: Elektrická 6471, 911 01 Trenčín, Slovakia

CRN: 36311723

VAT ID: SK2020177082

Phone: +421(0)326 526 701

E-mail: [objednavky@insportline.sk](mailto:objednavky@insportline.sk)

[reklamacie@insportline.sk](mailto:reklamacie@insportline.sk)

[servis@insportline.sk](mailto:servis@insportline.sk)

Web: [www.insportline.sk](http://www.insportline.sk)

Date of Sale:

Stamp and Signature of Seller: